

Polarization Quadrature Interferometer

Donald Gavel, UCSC Laboratory for Adaptive Optics

This memo describes a Mach-Zehnder interferometer setup that will measure the phase of an optic to the spatial resolution of the detector, using a polarization based quadrature detection technique. The approach was demonstrated by K. Baker at LLNL. We will use the interferometer in the MCAO testbed to characterize the response of Programmable Phase Modulators (PPM).

The Mach-Zehnder layout is shown below.

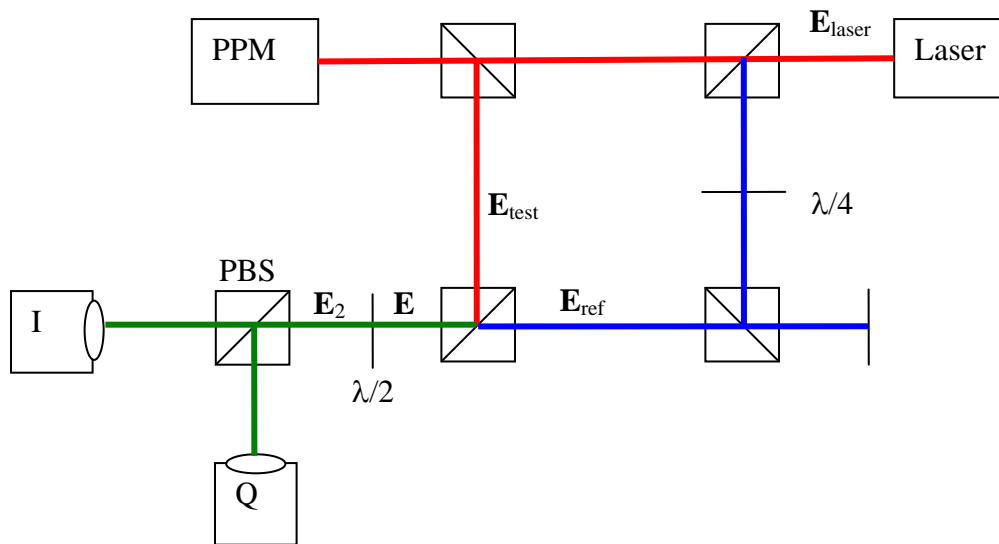

A quarter wave plate in the reference leg converts the laser's linearly polarized light into circular polarization. When the beams combine, the sine and cosine information from the device under test (PPM) is encoded on the 45° and 135° components of the electric field vector (see below). After the beam combiner plate, a half wave plate rotates the coordinate system 45° so that the encoding is on 0° and 90° components and a subsequent polarization beam splitter can separate channels. On the I channel is $1+\cos(\phi)$ and on the Q channel is $1+\sin(\phi)$. The data gathering computer does a bias subtraction and inverse tangent to get the 4-quadrant phase map of the PPM. Subsequent processing unwraps this phase.

Electric Field Vector

The laser produces the plane wave

$$\begin{aligned}
 \vec{E}_{laser} &= \hat{x}A_0 \cos \omega t \\
 &= \hat{x}'A \cos \omega t + \hat{y}'A \cos \omega t
 \end{aligned}
 \tag{1}$$

where \mathbf{E} is the electric field vector, $\hat{\mathbf{x}}$ and $\hat{\mathbf{y}}$ are unit vectors in the plane of the table and orthogonal to the table respectively, $\omega=2\pi c/\lambda$ is the temporal frequency of the light, A_0 is the amplitude of the plane wave and $A = A_0/\sqrt{2}$. $\hat{\mathbf{x}}'$ and $\hat{\mathbf{y}}'$ are unit vectors in a coordinate frame rotated 45 degrees from $\hat{\mathbf{x}}$ and $\hat{\mathbf{y}}$. This beam after it hits the device under test is

$$\bar{\mathbf{E}}_{test} = \hat{\mathbf{x}}'A \cos(\omega t + \phi) + \hat{\mathbf{y}}'A \cos(\omega t + \phi) \quad (2)$$

where $\phi = \phi(x, y)$ is the phase aberration of the wavefront.

In the reference arm, the plane wave is converted from linear to circular polarization after the $\lambda/4$ plate. This produces the wave

$$\begin{aligned} \bar{\mathbf{E}}_{ref} &= \hat{\mathbf{x}}A \cos \omega t + \hat{\mathbf{y}}A \sin \omega t \\ &= \hat{\mathbf{x}}'A \cos \omega t + \hat{\mathbf{y}}'A \sin \omega t \end{aligned} \quad (3)$$

Note that since the light is circularly polarized, it doesn't matter that the coordinate system is rotated by 45° .

At the combination plate, the waves are added coherently

$$\begin{aligned} \bar{\mathbf{E}} &= \bar{\mathbf{E}}_{test} + \bar{\mathbf{E}}_{ref} \\ &= \hat{\mathbf{x}}'A[\cos(\omega t + \phi) + \cos(\omega t)] + \hat{\mathbf{y}}'A[\cos(\omega t + \phi) + \sin(\omega t)] \end{aligned} \quad (4)$$

Note that the test beam exactly overlaps the reference beam; there is no shear or tilt to introduce fringes. This is optimal for minimizing non-common path aberrations through subsequent powered optics, since the two beams follow the same path.

The half wave plate then rotates the coordinate system back to orthogonal with the table

$$\bar{\mathbf{E}}_2 = \hat{\mathbf{x}}A[\cos(\omega t + \phi) + \cos(\omega t)] + \hat{\mathbf{y}}A[\cos(\omega t + \phi) + \sin(\omega t)]. \quad (5)$$

A polarizing beam splitter then separates the wave into the x and y components.

Detection

The camera detects the power in the waves according to a square-law:



$$\begin{aligned} I &= |E_x|^2 = A^2 [\cos^2(\omega t + \phi) + \cos^2(\omega t) + \cos(2\omega t + \phi) + \cos \phi] \\ Q &= |E_y|^2 = A^2 [\cos^2(\omega t + \phi) + \sin^2(\omega t) + \sin(2\omega t + \phi) - \sin \phi] \end{aligned} \quad (6)$$

Since we integrate the detector over many periods of the light wave, the time-average signal is recorded

$$\begin{aligned} \bar{I} &= A^2(1 + \cos \phi) \\ \bar{Q} &= A^2(1 - \sin \phi) \end{aligned} \quad (7)$$

We should note that the cameras are optically imaged to the plane of the device under test so as to minimize the effects of diffraction in this analysis.

Processing

Determining the Amplitude

The computer processing consists of subtracting the bias, taking the arctangent, then, finally, unwrapping the phase. To measure the bias, one can block the test arm of the interferometer and measure the reference beam only, in which case $\bar{I} = \bar{Q} = A^2/2$. This method is sensitive to the assumption that the intensity in the two arms is balanced and is sensitive to any fluctuations in laser power between intensity-only and interferogram measurements.

An alternative is to try to use the data itself to find A . From (7)

$$\begin{aligned} A^2 \cos \phi &= \bar{I} - A^2 \\ -A^2 \sin \phi &= \bar{Q} - A^2 \\ A^4 \sin^2 \phi + A^4 \cos^2 \phi &= \bar{Q}^2 + \bar{I}^2 - 2A^2(\bar{Q} + \bar{I}) + 2A^4 \\ 0 &= \bar{Q}^2 + \bar{I}^2 - 2A^2(\bar{Q} + \bar{I}) + A^4 \end{aligned} \quad (8)$$

The last equation is a quadratic form that can be solved for A^2 . The solution is

$$A^2 = \bar{I} + \bar{Q} \pm \sqrt{2\bar{I}\bar{Q}} \quad (9)$$

Unfortunately, there is no way to break the ambiguity of the sign choice from the data alone (i.e. there are always two sets of feasible $\{A^2, \phi\}$ solutions). To help determine the true value of A one can choose the one that is closest to an initial estimate of A obtained using one of the other methods mentioned earlier.

Determining the phase

Once the amplitude is determined, the phase modulo 2π is

$$\phi(x, y) = -\tan^{-1} \left[\frac{\overline{Q}(x, y) - A^2(x, y)}{\overline{I}(x, y) - A^2(x, y)} \right] \quad (10)$$

where we've reintroduced the transverse spatial coordinates x and y to highlight the fact that this measurement can be made at the pixel resolution of the camera. In software, the "Arctangent" implied in (10) is actually an "ArcTan2" function, with two arguments (the numerator and the denominator). This preserves the phasor's quadrant information so that the output spans a full range of $-\pi$ to $+\pi$.

Phase unwrapping

Assuming that the phase does not change too rapidly with x and y , the final step is to use phase unwrapping to get the full phase map. We use a technique (implemented in the IDL routing unwrap.pro) that is loosely outlined as:

- Calculate the gradient of phase, $\nabla\phi$. This converts 2π phase jumps into spikes.
- Add or subtract 2π to the spikes to keep all phase jumps in the $(-\pi, +\pi]$ range
- Reconstruct ϕ given $\nabla\phi$ with a Poisson's equation solver (described below)

The method of reconstructing phase from gradient is based on use of the Fourier Transform, defined as:

$$\begin{aligned} \tilde{\phi}(k_x, k_y) &= \iint \phi(x, y) e^{-2\pi i(k_x x + k_y y)} dx dy \\ \phi(x, y) &= \iint \tilde{\phi}(k_x, k_y) e^{2\pi i(k_x x + k_y y)} dk_x dk_y \end{aligned} \quad (11)$$

The gradient $\nabla\phi$ has the following Fourier transform pair

$$\nabla\phi(x, y) = \begin{pmatrix} \partial\phi/\partial x \\ \partial\phi/\partial y \end{pmatrix} \leftrightarrow 2\pi i \begin{pmatrix} k_x \\ k_y \end{pmatrix} \tilde{\phi}(k_x, k_y) = 2\pi i \mathbf{k} \tilde{\phi} \quad (12)$$

which can be verified by taking the derivative of the second equation in (11). Reconstruction of ϕ given $\nabla\phi$ is then equivalent to finding $\tilde{\phi}$ given $\mathbf{k}\tilde{\phi}$. The least-squares solution is

$$\tilde{\phi}(\mathbf{k}) = \frac{-i\mathbf{k}}{2\pi k^2} \cdot (2\pi i \mathbf{k} \tilde{\phi}) \quad (13)$$

where $k = |\mathbf{k}| = \sqrt{k_x^2 + k_y^2}$, or

$$\phi(\mathbf{x}) = FT_{\mathbf{k} \rightarrow \mathbf{x}}^{-1} \left\{ \frac{-i\mathbf{k}}{2\pi k^2} \cdot FT_{\mathbf{x} \rightarrow \mathbf{k}} \{ \nabla \phi(\mathbf{x}) \} \right\} \quad (14)$$

where FT represents the Fourier transform.

First order analysis of split imbalance

Real-world beam splitters are not perfect, thus there is a misbalance in the intensities of the light in each of the Mach-Zehnder interferometer arms and in each of the camera channels. To take this into account, Zhenrong Wang has performed a first-order analysis of the affects of these imbalances and has incorporated the results into the data processing software¹.

Let α^2 be the ratio of P to S polarization output intensities after the polarizing beam splitter, assuming a circular polarized beam input. P polarization transmits through the splitter and goes into the I channel camera and S polarization reflects off the splitter and goes into the Q channel camera. Let β^2 be the ratio of the two interferometer arms' throughputs so $\beta = |E_{ref}|/|E_{test}|$ (which includes reflecting off the SLM in the test arm). Nominally, both ratios are equal to one. The resulting fields are

$$\begin{aligned} \vec{\mathbf{E}}_{test} &= \hat{\mathbf{x}}'A \cos(\omega t + \phi) + \hat{\mathbf{y}}'A \alpha \cos(\omega t + \phi) \\ \vec{\mathbf{E}}_{ref} &= \hat{\mathbf{x}}'\beta A \cos \omega t + \hat{\mathbf{y}}'A \alpha \beta \sin \omega t \end{aligned} \quad (15)$$

so

$$\vec{\mathbf{E}} = \vec{\mathbf{E}}_{test} + \vec{\mathbf{E}}_{ref} = \hat{\mathbf{x}}'A[\cos(\omega t + \phi) + \beta \cos(\omega t)] + \hat{\mathbf{y}}'A[\cos(\omega t + \phi) + \beta \sin(\omega t)] \quad (16)$$

and the intensities detected in the I and Q channels are

$$\begin{aligned} \bar{I} &= \langle |E_{x'}|^2 \rangle_t = A^2 \left(\frac{1 + \beta^2}{2} + \beta \cos \phi \right) \\ \bar{Q} &= \langle |E_{y'}|^2 \rangle_t = A^2 \alpha^2 \left(\frac{1 + \beta^2}{2} - \beta \sin \phi \right) \end{aligned} \quad (17)$$

Let $\bar{I}' = 2\bar{I}/(1 + \beta^2)$ and $\bar{Q}' = 2\bar{Q}/\alpha^2(1 + \beta^2)$. Then

$$\begin{aligned} \bar{I}' &= A^2(1 + m \cos \phi) \\ \bar{Q}' &= A^2(1 - m \sin \phi) \end{aligned} \quad (18)$$

where $m = 2\beta/(1 + \beta^2)$.



Photometric measurements have determined the following:

$$\begin{aligned}\alpha^2 &= 1.064 \\ \beta^2 &= 1.2 \\ m &= 0.996\end{aligned}\tag{19}$$

Since m is very nearly one, the processing steps can proceed using the modified \bar{I}' and \bar{Q}' signals as defined above with less than 0.4% error, whereas using the unmodified signals would introduce on the order of 10% error.

References

¹Zhenrong Wang, "[Characterization of Programmable Phase Modulator with Polarization Quadrature Interferometer](#)", master's thesis, UC Santa Cruz, Sept. 2004.